

# City of Montgomery, Alabama - Grading Permit Packet

---

PLEASE NOTE: 3,500 square feet of disturbance that are less than 2-feet in depth or a cut greater than 5-feet or steeper than 2 to 1 are the thresholds for all grading permits. See Article II, Sections 8 and 9 of the ordinance for additional exceptions to the Grading Permit requirement.

This Packet contains:

- (1) Grading Permit Fee and Bond Fee Schedule
- (2) Application for Grading Permit
- (3) Information on ADEM General NPDES Permit No. ALR100000 Construction Site Permit requirements
- (4) Typical Erosion and Sediment Control details for Construction of Single Family Residence
- (5) Typical Narrative for Construction of Single Family Residence
- (6) Checklist guide for preparation of an Erosion and Sediment Control Plan
- (7) Corporate Surety Bond forms (only one of two required) to be completed by your bonding company, and
- (8) Site Clearing, Earthwork, Grading and other Site Activity Letter of Credit Form
- (9) See City Web site for Montgomery Priority Watershed maps; Three Mile Branch and Jenkins Creek

To fill out the Grading Permit Application:

- Fill out the Application ENTIRELY. Do not leave any blank lines. If any information is found to be incomplete or inaccurate, the application will not be accepted. This may delay review and/or approval of your application.
- Include the Property I.D. (County Tax Map) number(s) available from the land records or the Real Estate Tax Map. If you do not know the ID number(s), it is obtainable from the City of Montgomery Internet GIS (<http://gis.montgomeryal.gov/gisviewer/>).
- Calculate an accurate estimate of the total disturbed acres to the nearest hundredth. (For example: 1.55 acres) This will be used to calculate the bond amount.
- Please include the purpose of the project (top of page one). For example: "water and sewer utility" or "residential subdivision" or "neighborhood playground" or "architectural berm" etc.
- The application MUST be signed by the property owner or authorized agent (page two). If an authorized agent signs, please provide a copy of authorization from the owner.
- Complete contact information must be provided (page one middle). City inspectors will attempt to contact the site supervisor however; copies of all inspections, warnings, compliance order, stop work orders, violations and abatement or remediation orders are the responsibility of the property owner and will be sent to the property owner on file.
- Notification to the site supervisor and/or CBMPP or QCP contact is a courtesy of the City. Property owner shall be considered liable for any permit violation or fines.
- Include Letters of Permission for any related off-site land disturbance.
- Provide copy of the NPDES construction permit (if required) from the Alabama Department of Environmental Management (ADEM). Information about the permit is available at ADEM website ([www.adem.state.al.us/programs/water/constructionstormwater.cnt](http://www.adem.state.al.us/programs/water/constructionstormwater.cnt)). A copy of these pages is included in this information packet. Please see the ADEM Web site for the latest information updates. In most cases, only the NPDES permit application is required with the application.

Submit the application to the 1<sup>st</sup> Floor, City of Montgomery, Building Department, Permits Counter, Room 106, 25 Washington Street, Montgomery Alabama:

- You must submit the following:
  - 1) Grading Permit Application
  - 2) Fee check
  - 3) Any other necessary permits or letters
  - 4) Erosion & Siltation control bond estimate based on total disturbed area (see the enclosed Fees and Bond schedule)
  - 5) Two complete sets of plans to include the Erosion & Siltation Control Plan (in a Phase I and Phase II format, only if necessary by project complexity)
- PLEASE take care in calculating your fee – if the fee has not been calculated correctly, the application will not be accepted.
- The Erosion and Sediment Control Engineering Technician for the City of Montgomery will contact you with comments to be addressed or written approval.

Upon written grading plan approval notification by the City, please submit your bond (or letter of Credit) documents and surety to the 2<sup>nd</sup> Floor, City of Montgomery, Engineering and Environmental Services, Room 206, 25 Washington Street, Montgomery Alabama:

- Bring a copy of your grading plan approval letter, one additional copy of the plans and the appropriate collateral in the form of
  - 1) Cashiers or certified check (a W-9 form and e-verify is required with all cash submittals)
  - 2) A Letter of Credit, or
  - 3) Corporate Surety Bond, for the amounts specified on the approval letter or Grading Permit Application.

Upon approval of the bond by the City:

- A City Engineering Technician will contact the applicant within ten (10) workdays of receipt of a complete plan submission with comments or plan approval. *The Grading Permit will be issued upon plan approval.*

**Only, if stated in your plan approval letter, an onsite pre-construction meeting is required prior to any land disturbance:**

- A City Engineering inspector will contact the applicant within ten (10) workdays to schedule the pre-construction meeting. *The Grading Permit will be issued at the Pre-Construction Meeting*
- The pre-construction meeting requires:
  - 1) The Limits of Clearing must be flagged prior to the meeting
  - 2) The final approval of an ADEM NPDES Land Disturbance Permit (if required)
  - 3) The site superintendent, clearing and/or grading contractor and any companies responsible for site inspections and/or BMP installation attendance

# GRADING AND BOND FEES

<b>GRADING PERMIT FEES:</b>	
<b>Permit Application Fee –</b> Commercial (Development Plans, DP), Subdivisions and Infrastructure Plans	<b>\$ 400.00</b>
<b>Single Family Detached Residential</b>	<b>Exempt from application fee</b> , please note “Exempt” on the permit application
<b>BOND AMOUNTS REQUIRED FOR DEVELOPMENT:</b>	
<b>Clearing Operations Only</b>	<b>\$ 1,000 per acre or fraction of disturbed acre</b>
<b>Earthwork or Clearing &amp; Earthwork Operations</b>	<b>\$ 3,000 per acre or fraction of disturbed acre</b>
<b>Clearing Operations in Floodway, Floodplain or Unstable slopes</b>	<b>\$ 2,000 per acre or fraction of disturbed acre</b>
<b>Earthwork or Clearing &amp; Earthwork in Floodway, Floodplain or Unstable slopes</b>	<b>\$ 6,000 per acre or fraction of disturbed acre</b>
INSPECTIONS FOR PROJECT COMPLETION INCLUDES ONE PUNCH LIST INSPECTION AND ONE FINAL INSPECTION; IF FURTHER INSPECTIONS ARE REQUIRED TO VERIFY THE PROJECT IS COMPLETED AND READY FOR BOND RELEASE, A \$500 RE-INSPECTION FEE IS REQUIRED.	

**COMMENT:**

- Single Family Detached houses are exempt from the \$400 application fee only; all other requirements of ordinance are effective.
- In general, all Development Plans (DPs) are considered commercial projects and the bonds are calculated on total disturbed acreage.
- Construction Plans and Profiles (CPAP) and infrastructure projects bonds are calculated on total disturbed acreage.
- Single family house construction is required to apply of a separate grading permit from the subdivision plans. At the owner’s options, the subdivision bond may be applied to the house grading in lieu of a separate bond.
- Any project which is submitted as a “Rough Grading” or Temporary Stockpile permit will also have to apply for an additional grading permit and bond upon final grading plan approval.

When calculating bond amount, please use an accurate estimate of the disturbed acres to the nearest hundredth (For example: 1.55 acres).

**\*EXAMPLE CALCULATION: For a project that is disturbing 4.42 acres (or rounded to 5 acres), the fee would be calculated as: (5 x \$3,000) = \$15,000.00 Total Bond Amount**

# Grading Permit Application Directions Notes

## A. Property Location and General Information

- 1) Colored box is for City use

## B. Contact Information

- 1) Property Owner should be the deeded Owner of the property, not the builder's client

## C. Regulatory Requirements

- 1) Requirements are to be determined by the permit applicant
- 2) See watershed maps for Priority Construction Sites within the City of Montgomery
- 3) See information on ADEM General Construction Permits enclosed
- 4) If applicant will use an overall plans that were submitted under a prior application, please note the original permit application number

## D. Certification

## E. Owner and Applicant Signatures

- 1) If there is more than one property owner, please provide an additional addendum sheet with all the appropriate owner signatures, or the application will not be valid.
- 2) If the applicant is signing on behalf of the owner/owners, you must provide authorization.

**GRADING PERMIT APPLICATION**  
City of Montgomery, AL

**PROPERTY LOCATION AND GENERAL INFORMATION**

Project Name: _____	Permit Number: _____
Site Location /Address: _____ _____	DATE: _____ FEE: _____ BOND AMOUNT: _____

Description of Work: \_\_\_\_\_ Disturbed Area \_\_\_\_\_ Acres

Proposed Use: \_\_\_\_\_  
\_\_\_\_\_

Permit Type:  Clearing     Clearing/Grading    Property Type:  Commercial/Subdivision     Residential Single-Family

**CONTACT INFORMATION**

Property Owner: \_\_\_\_\_ Company: \_\_\_\_\_  
Address: \_\_\_\_\_  
City: \_\_\_\_\_ State: \_\_\_\_\_ ZIP Code: \_\_\_\_\_  
Phone: \_\_\_\_\_ Cell: \_\_\_\_\_ Email: \_\_\_\_\_

Site Supervisor: \_\_\_\_\_ Company: \_\_\_\_\_  
Address: \_\_\_\_\_  
City: \_\_\_\_\_ State: \_\_\_\_\_ ZIP Code: \_\_\_\_\_  
Phone: \_\_\_\_\_ Cell: \_\_\_\_\_ Email: \_\_\_\_\_

CBMPP or QCP Contact: \_\_\_\_\_ Company: \_\_\_\_\_  
Address: \_\_\_\_\_  
City: \_\_\_\_\_ State: \_\_\_\_\_ ZIP Code: \_\_\_\_\_  
Phone: \_\_\_\_\_ Cell: \_\_\_\_\_ Email: \_\_\_\_\_  
Comments: \_\_\_\_\_

**REGULATORY REQUIREMENTS**

Is construction project a Priority Construction Site?	Yes <input type="checkbox"/>	No <input type="checkbox"/>
Does project require ADEM NPDES Permit?	Yes <input type="checkbox"/>	No <input type="checkbox"/>
If yes, NPDES Permit Number _____	(required)	Type _____
Erosion & Siltation Control Plan attached?	Yes <input type="checkbox"/>	No <input type="checkbox"/>
Concrete washout, chemicals, litter and sanitary waste control plan?	Yes <input type="checkbox"/>	No <input type="checkbox"/>
Check if prior Permit Plan or Bond <input type="checkbox"/>		Prior Permit No. or Bond No. _____
Engineering Department plan approval?	Yes <input type="checkbox"/>	No <input type="checkbox"/>
Approved by?		_____

# GRADING PERMIT APPLICATION

CITY OF MONTGOMERY, AL

## CERTIFICATION

### **EXPIRATION:**

Grading Permit application shall expire in six (6) months from the date of submittal, if the collateral (surety, letter of credit or cash) and has not been approved and a grading/building permit issued for this project. Once a grading permit is issued, the duration of the permit shall be in effect for no longer than three (3) three years after the date of issuance.

### **RIGHT OF ENTRY:**

I hereby grant designated officials of City of Montgomery the right to enter my property for the purpose of inspection or monitoring for compliance with the approved erosion and sediment control plan on the above referenced project.

### **PLAN IMPLEMENTATIONS:**

I certify that I fully understand and will comply with all City of Montgomery Erosion and Sediment Control Program requirements and the *Alabama Handbook for Erosion, Sediment Control and Stormwater Management on Construction Sites* or industry standards as accepted by ADEM. I will carry out the erosion and sediment control plan on the above referenced project as approved by the City of Montgomery. I will keep a copy of the most current Alabama Handbook or field manual and one set of the approved Erosion Control Plan on the referenced site at all times.

## OWNER AND APPLICANT SIGNATURES

I certify, under penalty of law, that this document and all attachments were prepared under my direction or supervision, and I am familiar with, the information in this document and such attachments. Based on my inquiry of those individuals immediately responsible for obtaining the information or of the Qualified Credentialed Professional responsible for preparing any portion of the application or correspondence, I believe the submitted information is true, accurate and complete. I am aware that there are significant penalties for submitting false information, including the possibility of fine and civil penalty.

\_\_\_\_\_  
*Printed name and Title of Applicant*

\_\_\_\_\_  
*Signature of Applicant*

\_\_\_\_\_  
*Date*

\_\_\_\_\_  
*Printed name and Title of Owner*

\_\_\_\_\_  
*Signature of Owner*

\_\_\_\_\_  
*Date*

Note: *Shaded text is for City use only.*

## ADEM - Construction General Permit

<http://www.adem.state.al.us/programs/water/constructionstormwater.cnt>

The Clean Water Act and Federal regulations require construction site operators to obtain NPDES permit coverage for regulated land disturbances and associated discharges of stormwater runoff to State waters.

Effective April 1, 2011, ADEM established General NPDES Permit No. ALR100000 for discharges associated with regulated construction activity that will result in land disturbance equal to or greater than one acre or from construction activities involving less than one acre and which are part of a common plan of development or sale equal to or greater than one acre.

Construction site operators / owners seeking coverage under this general permit must submit a Notice of Intent (NOI) in accordance with the permit requirements.

Operators / owners of all regulated construction sites must implement and maintain effective erosion and sediment controls in accordance a Construction Best Management Practices Plan (CBMPP) prepared and certified by a Qualified Credentialed Professional (QCP). For priority construction sites, which include any site that discharges to (1) a waterbody which is listed on the most recently EPA approved 303(d) list of impaired waters for turbidity, siltation, or sedimentation, (2) any waterbody for which a TMDL has been finalized or approved by EPA for turbidity, siltation, or sedimentation, (3) any waterbody assigned the Outstanding Alabama Water use classification in accordance with ADEM Admin. Code r. 335-6-10-.09, and (4) any waterbody assigned a special designation in accordance with ADEM Admin. Code r. 335-6-10-.10, the CBMPP must be submitted to ADEM for review along with the NOI.

A QCP or Qualified Credentialed Inspector (QCI) conduct regular inspections of regulated construction activities to ensure effective erosion and sediment controls are being maintained. In certain circumstances, the QCI or QCP must also monitor construction site discharges for turbidity.

On December 1, 2009, the U.S. Environmental Protection Agency (EPA) published effluent limit guidelines (ELGs) and new source performance standards (NSPS) for regulated construction sites. The regulation was effective on February 1, 2010. After this date, all permits issued by EPA or states must incorporate the final rule requirements. Although certain parts of the rule were since stayed, ADEM's general permit incorporates those non-numeric effluent limits promulgated by EPA and which remain in effect.

### **Alabama Construction General Permit, April 1, 2011**

<http://www.adem.state.al.us/programs/water/waterforms/ALR10CGP.pdf>

#### **Construction General Permit Forms**

[CGP - Notice of Intent](http://www.adem.state.al.us/programs/water/waterforms/CSW-CGP-NOI.pdf) <http://www.adem.state.al.us/programs/water/waterforms/CSW-CGP-NOI.pdf>

[CGP - Inspection Report](http://www.adem.state.al.us/programs/water/waterforms/CSW-CGP-InspectionReport.pdf) <http://www.adem.state.al.us/programs/water/waterforms/CSW-CGP-InspectionReport.pdf>

[CGP - Notice of Noncompliance](http://www.adem.state.al.us/programs/water/waterforms/CSW-CGP-Noncompliance.pdf) <http://www.adem.state.al.us/programs/water/waterforms/CSW-CGP-Noncompliance.pdf>

[CGP - Termination Request](http://www.adem.state.al.us/programs/water/waterforms/CSW-CGP-NOT.pdf) <http://www.adem.state.al.us/programs/water/waterforms/CSW-CGP-NOT.pdf>

**NOW AVAILABLE: eNOI** <https://app.adem.alabama.gov/eNOI/>

ADEM's construction general permit requires the registrant to post and maintain facility identification. The registrant is required to post a sign at easily accessible location(s) to identify the site. The registrant may use this example sign or create and use a sign with equivalent identifying information.

[Example Facility ID Sign](http://www.adem.state.al.us/programs/water/waterforms/CSW-CGP-FacilitySignExample.doc) <http://www.adem.state.al.us/programs/water/waterforms/CSW-CGP-FacilitySignExample.doc>

[Permit Fee Schedule D](http://www.adem.state.al.us/programs/water/waterforms/FeeScheduleD.pdf) <http://www.adem.state.al.us/programs/water/waterforms/FeeScheduleD.pdf>

[Updated ADEM CBMPP Template](http://www.adem.state.al.us/programs/water/waterforms/CSW-CBMPPTemplate.pdf) <http://www.adem.state.al.us/programs/water/waterforms/CSW-CBMPPTemplate.pdf>

[AL Handbook for Erosion Control, Sediment Control and Stormwater management on Construction Sites and Urban Areas](http://swcc.alabama.gov/pages/erosion_control.aspx?sm=b_b) [http://swcc.alabama.gov/pages/erosion\\_control.aspx?sm=b\\_b](http://swcc.alabama.gov/pages/erosion_control.aspx?sm=b_b)

## Priority Construction Sites

Construction sites discharging directly to these waters, and those within any identified watershed areas, will be required to submit a CBMPP with any request for permit coverage. For waters where only the stream segment is identified, ADEM may still, on a case-by-case, designate sites within the surrounding watershed as priority construction sites. Contact the Department for additional guidance. [Click here](#) for Priority Construction Sites Map.

[Construction Stormwater GIS Files](#) <http://www.adem.state.al.us/programs/water/waterforms/csw.zip>

[Alabama 303\(d\) list of Impaired Waters](#) <http://adem.alabama.gov/programs/water/303d.cnt>

[Information on Alabama TMDLs](#) <http://adem.alabama.gov/programs/water/tmdl.cnt>

## Qualified Credentialed Inspector Training

<http://www.adem.state.al.us/programs/water/waterforms/QCPQCIProg.pdf>

ADEM currently recognizes the following QCI Training Programs:

### Homebuilders Association of Alabama (HBAA)

[HBAA Qualified Credentialed Inspector \(QCI\) training program](#)

<http://hbaa.org/wp/>

### Thompson Engineering, Inc. (TEI)

[Thompson Engineering, Inc. \(TEI\) Qualified Credentialed Inspector \(QCI\) training program](#)

<http://thompsonengineering.com/>

## Contact Information

Mailing Address	Physical Address
<p style="text-align: center;"><b>ADEM</b> Attn: Water Division Stormwater Management Branch Post Office Box 301463 Montgomery, Alabama 36130-1463 (334) 271-7700 (334) 279-3051 Fax <a href="mailto:cswmail@adem.state.al.us">cswmail@adem.state.al.us</a></p>	<p style="text-align: center;"><b>ADEM</b> Attn: Water Division Stormwater Management Branch 1400 Coliseum Boulevard Montgomery, Alabama 36110 (334) 271-7700 (334) 279-3051 Fax <a href="mailto:cswmail@adem.state.al.us">cswmail@adem.state.al.us</a></p>



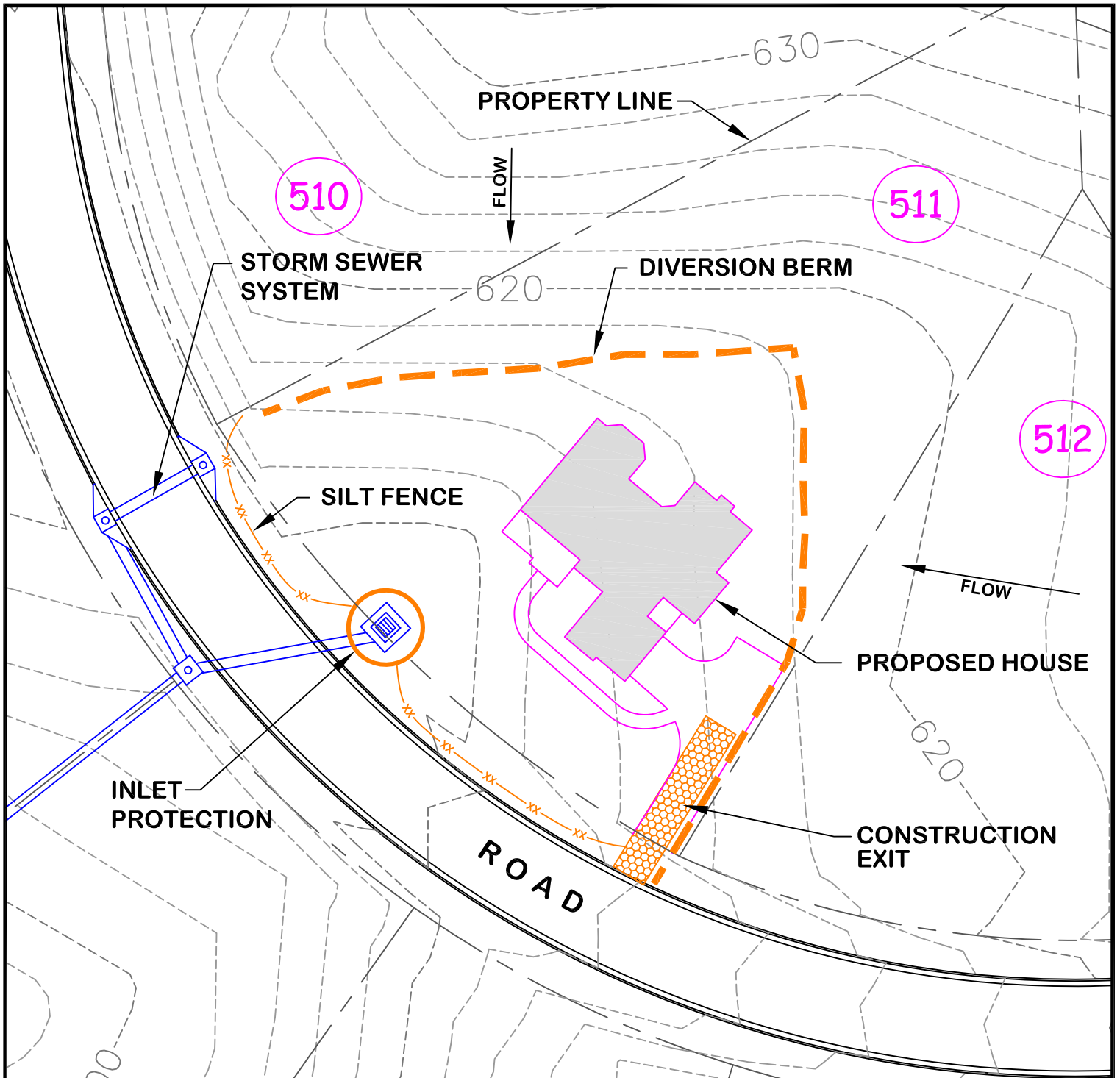

**FOR EXAMPLE ONLY**

THIS SITE PLAN SHOWS TYPICAL BMPs THAT ARE USED ON CONSTRUCTION SITES. THE DEVELOPER OF A CONSTRUCTION SITE IS RESPONSIBLE TO DEVELOP, INSTALL AND MAINTAIN BMPs THAT ARE SPECIFICALLY SELECTED FOR THEIR SITE. BMPs SHALL BE SELECTED, INSTALLED AND MAINTAINED IN ACCORDANCE WITH THE ALABAMA HANDBOOK FOR EROSION CONTROL, SEDIMENT CONTROL AND STORMWATER MANAGEMENT ON CONSTRUCTION SITES AND URBAN AREAS.

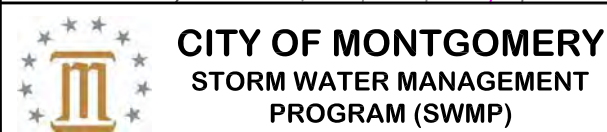

**CITY OF MONTGOMERY**  
**STORM WATER MANAGEMENT**  
**PROGRAM (SWMP)**

DATE  
**2 JULY 2012**

PREPARED BY  
**D. SMITH**

APPROVED BY  
**P. DUNSON**

HYDRO  
 ENGINEERING  
 SOLUTIONS, LLC

DRAWING NO.

**RES-ESCP**

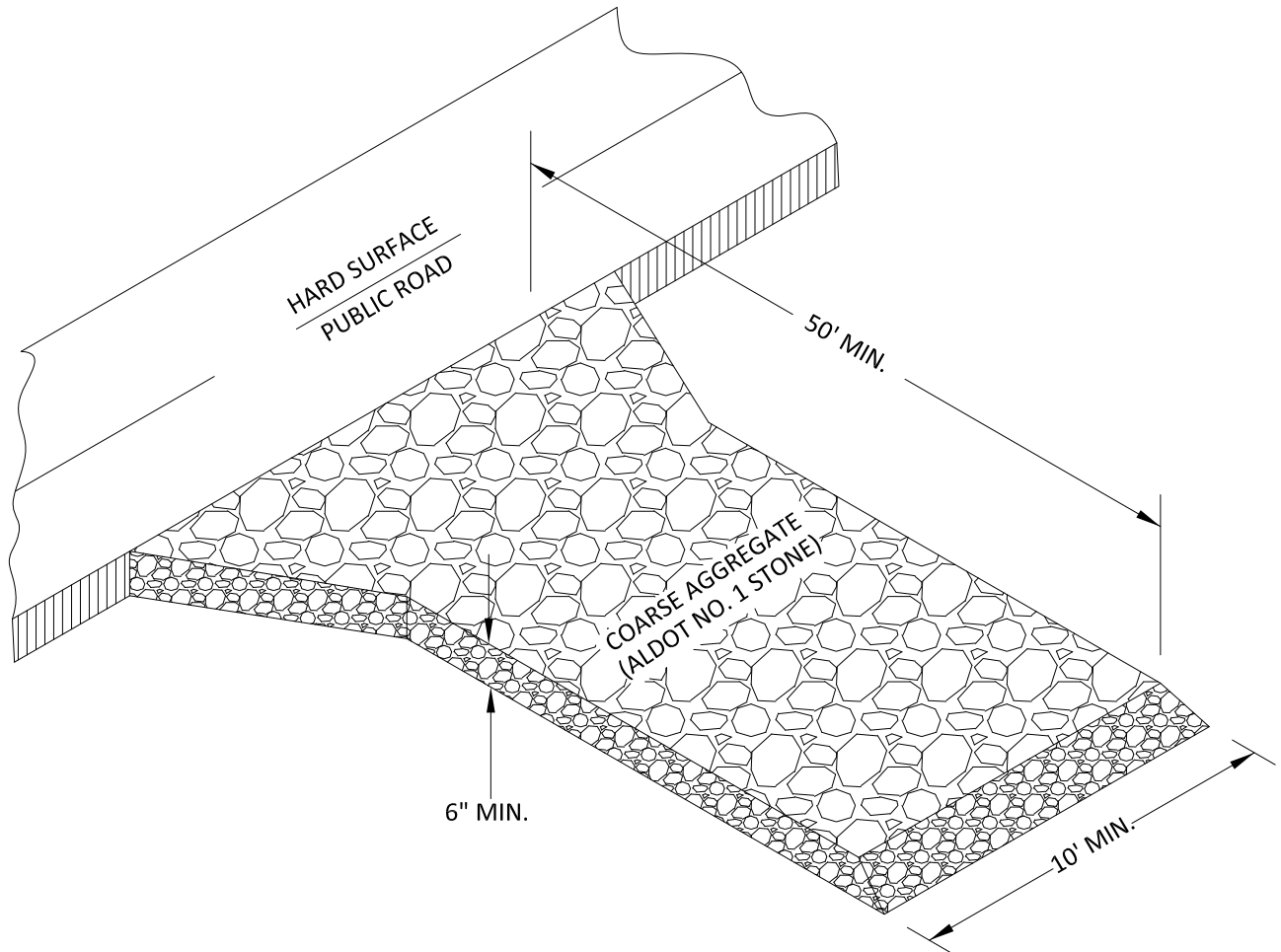

NOTE:

1. INSTALL CLASS IV NON-WOVEN GEOTEXTILE FABRIC UNDER THE ALDOT NO. 1 STONE TO EXTEND THE LIFE OF THE ENTRANCE.



**CITY OF MONTGOMERY**  
 STORM WATER MANAGEMENT  
 PROGRAM (SWMP)

DATE  
 9 JULY 2012  
 PREPARED BY  
 D. SMITH  
 APPROVED BY  
 P. DUNSON



DRAWING NO.

**RES-CEP**

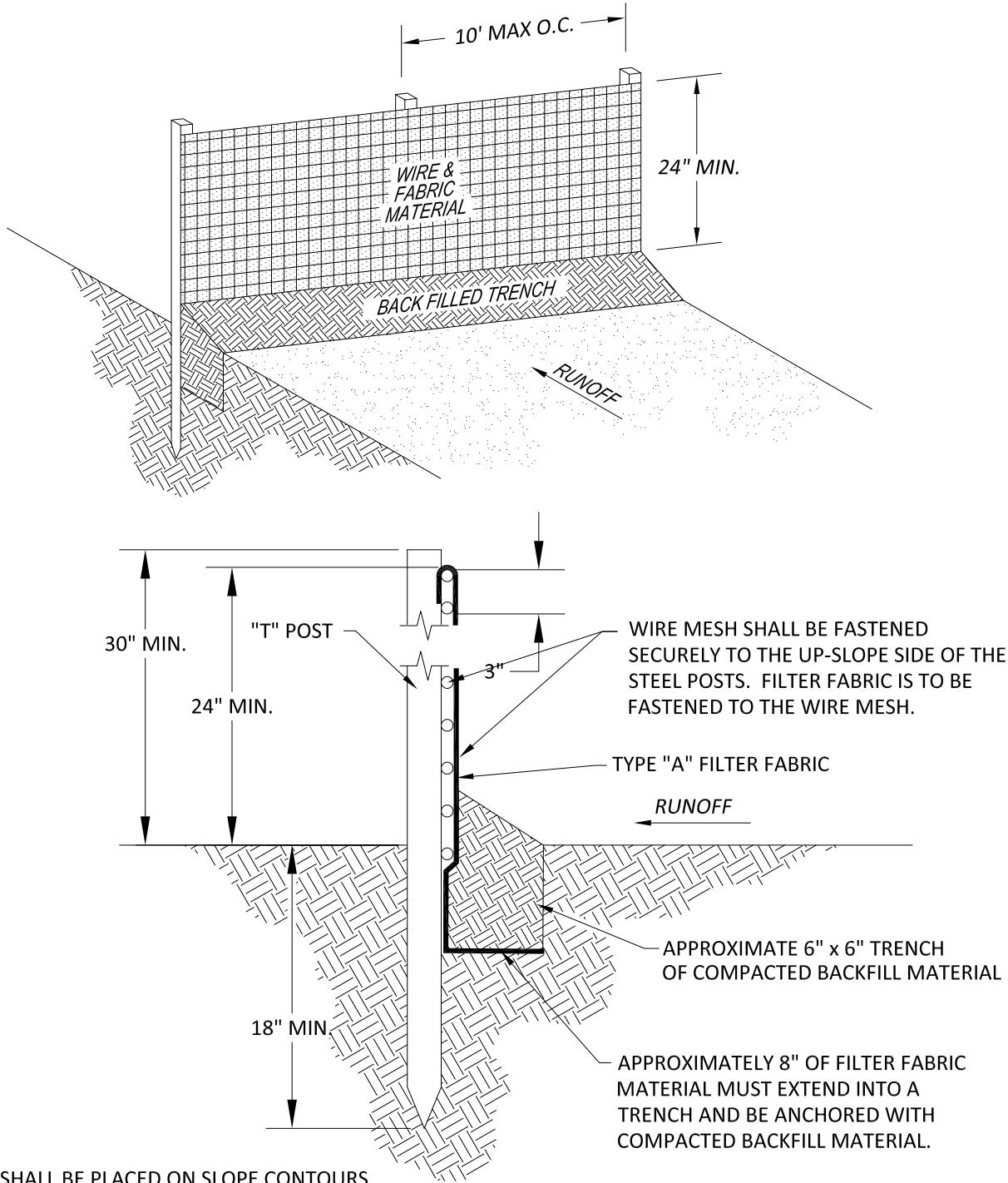

NOTES:

1. SILT FENCE SHALL BE PLACED ON SLOPE CONTOURS TO MAXIMIZE PONDING EFFICIENCY.
2. INSPECT AND REPAIR AFTER EACH STORM EVENT.
3. REMOVE SEDIMENT AS REQUIRED FOR PROPER OPERATION.

### TYPICAL FILL DIVERSION

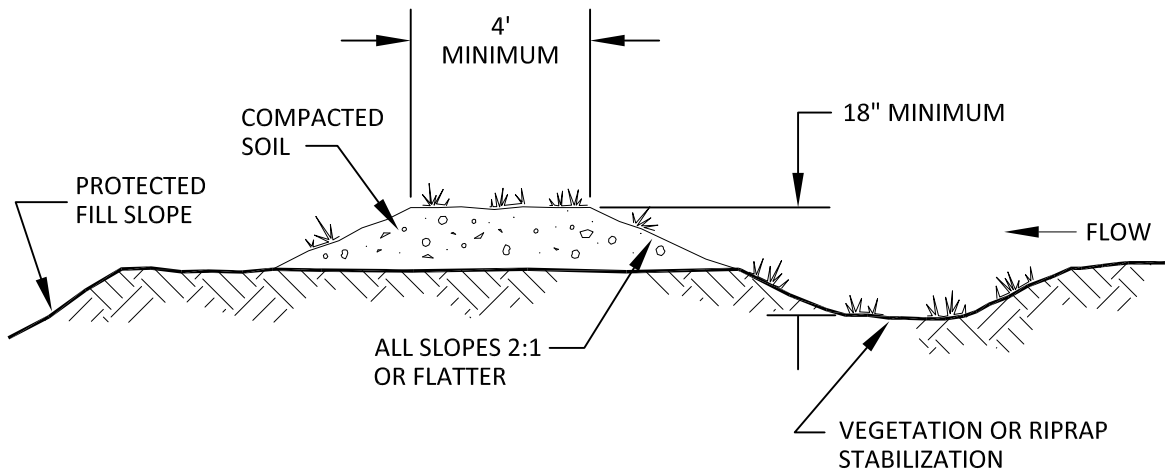

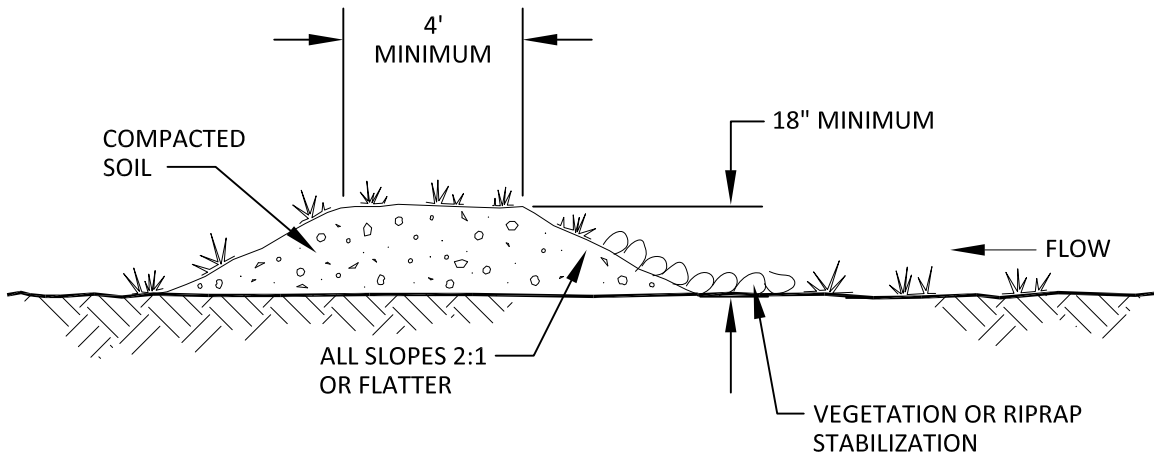

### TYPICAL TEMPORARY DIVERSION DIKE



**NOTES:**

1. THE CHANNEL BEHIND THE DIKE SHALL HAVE POSITIVE GRADE TO A STABILIZED OUTLET.
2. THE DIKE SHALL BE ADEQUATELY COMPACTED TO PREVENT FAILURE.
3. THE DIKE SHALL BE STABILIZED WITH TEMPORARY OR PERMANENT SEEDING OR RIPRAP.

 <p><b>CITY OF MONTGOMERY</b> STORM WATER MANAGEMENT PROGRAM (SWMP)</p>	DATE 9 JULY 2012	 <p>HYDRO ENGINEERING SOLUTIONS, LLC</p>	DRAWING NO.
	PREPARED BY D. SMITH		<p><b>RES-DVB</b></p>
	APPROVED BY P. DUNSON		
DRAWING TITLE DIVERSION (DV) - BERM			PAGE 4 OF 7

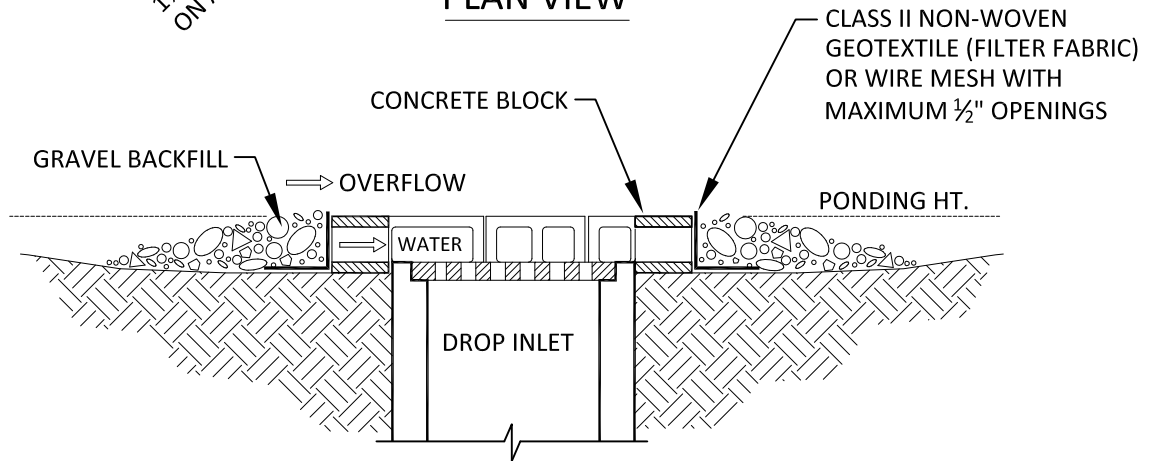
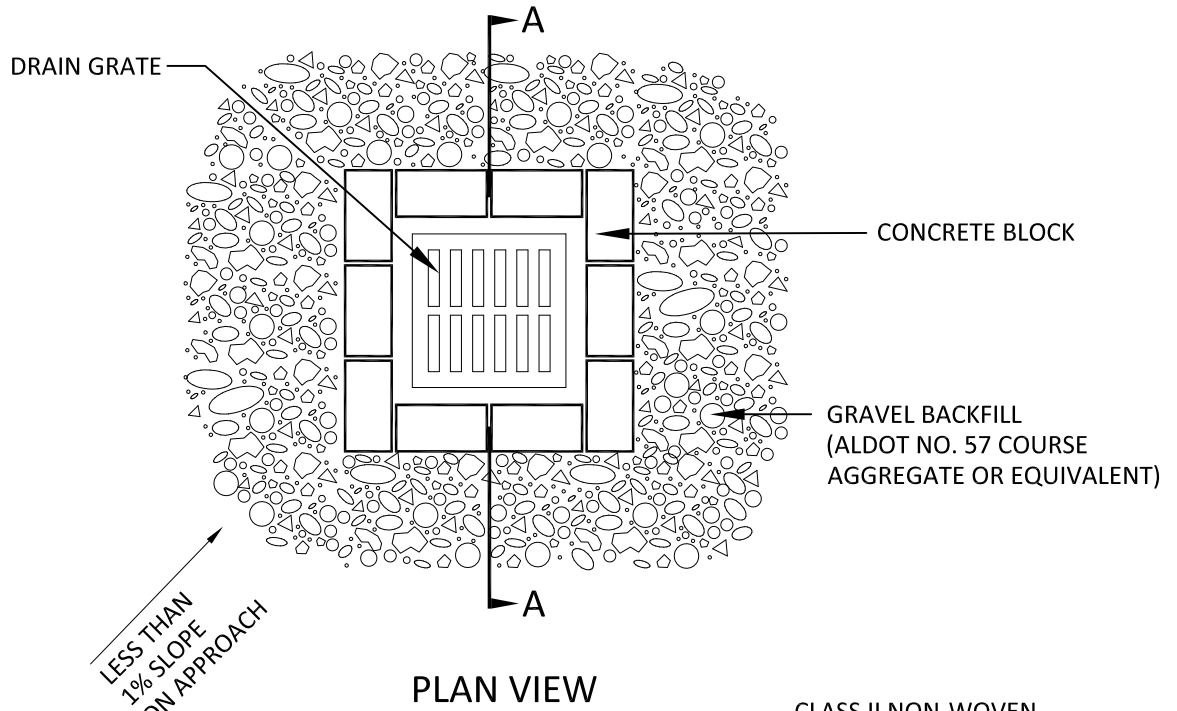

**SECTION A - A**

**NOTES:**

1. DROP INLET SEDIMENT BARRIERS ARE TO BE USED FOR SAMLL, NEARLY LEVEL DRAINAGE AREAS. (LESS THAN 5%)
2. EXCAVATE A BASIN OF SUFFICIENT SIZE ADJACENT TO THE DROP INLET.
3. THE TOP OF THE STRUCTURE (PONDING HEIGHT) MUST BE WELL BELOW THE GROUND ELEVATION DOWNSLOPE TO PREVENT RUNOFF FROM BYPASSING THE INLET. A TEMPORARY DIKE MAY BE NECESSARY ON THE DOWNSLOPE SIDE OF THE STRUCTURE.

<p><b>CITY OF MONTGOMERY</b> STORM WATER MANAGEMENT PROGRAM (SWMP)</p>	DATE 9 JULY 2012	<p>HYDRO ENGINEERING SOLUTIONS, LLC</p>	DRAWING NO.
	PREPARED BY D. SMITH		<b>RES-BIP</b>
	APPROVED BY P. DUNSON		
DRAWING TITLE	<b>BLOCK AND GRAVEL INLET PROTECTION (BIP)</b>		PAGE 5 OF 7

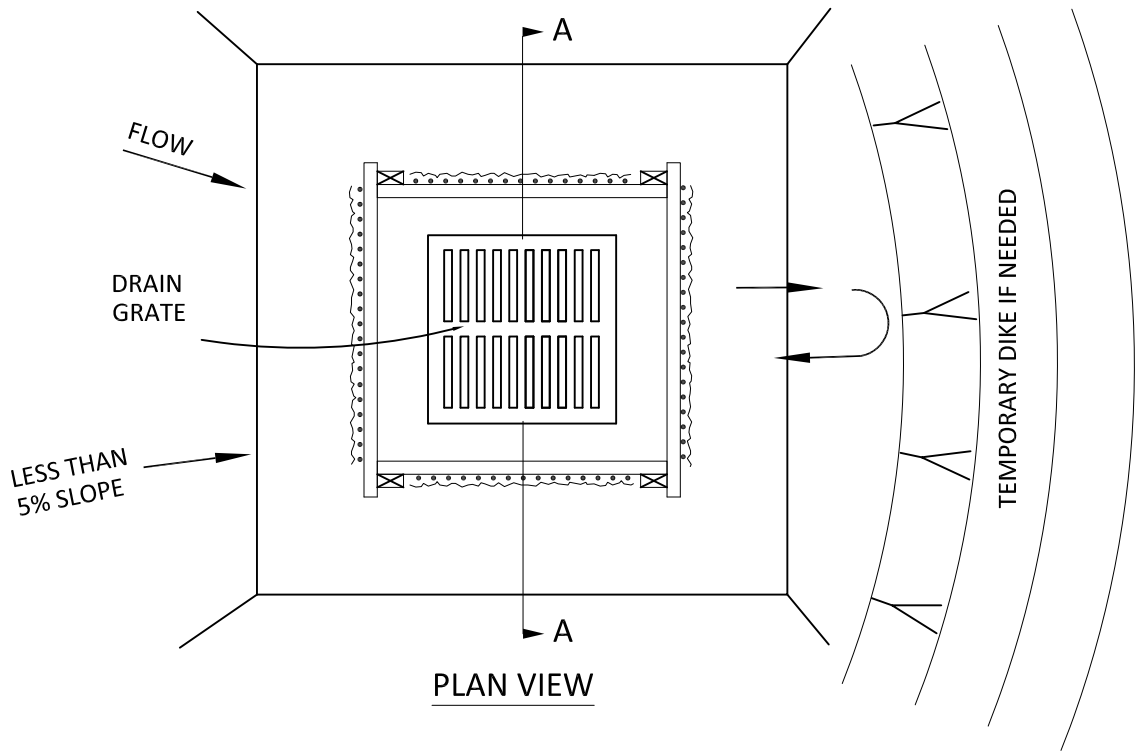

**PLAN VIEW**

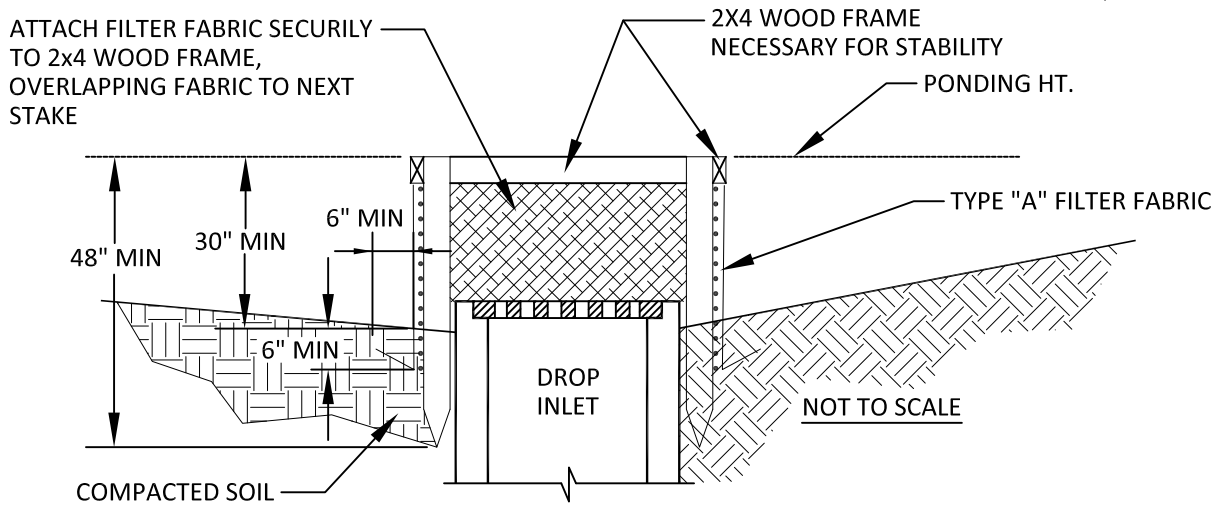

**SECTION A-A**

**NOTES:**

1. DROP INLET SEDIMENT BARRIERS ARE TO BE USED FOR SMALL, NEARLY LEVEL DRAINAGE AREAS. (LESS THAN 5%)
2. USE 2"x4" WOOD OR EQUIVALENT METAL STAKES, 4' MINIMUM LENGTH.
3. INSTALL 2"x4" WOOD TOP FRAME TO INSURE STABILITY.
4. THE TOP OF THE FRAME (PONDING HEIGHT) MUST BE WELL BELOW THE GROUND ELEVATION DOWNSLOPE TO PREVENT RUNOFF FROM BYPASSING THE INLET. A TEMPORARY DIKE MAY BE NECESSARY IN THE DOWNSLOPES SIDE OF THE STRUCTURE.



**CITY OF MONTGOMERY**  
 STORM WATER MANAGEMENT  
 PROGRAM (SWMP)

DATE  
 9 JULY 2012  
 PREPARED BY  
 D. SMITH  
 APPROVED BY  
 P. DUNSON



DRAWING NO.

**RES-IPSB**

# DOUBLE WING INLET

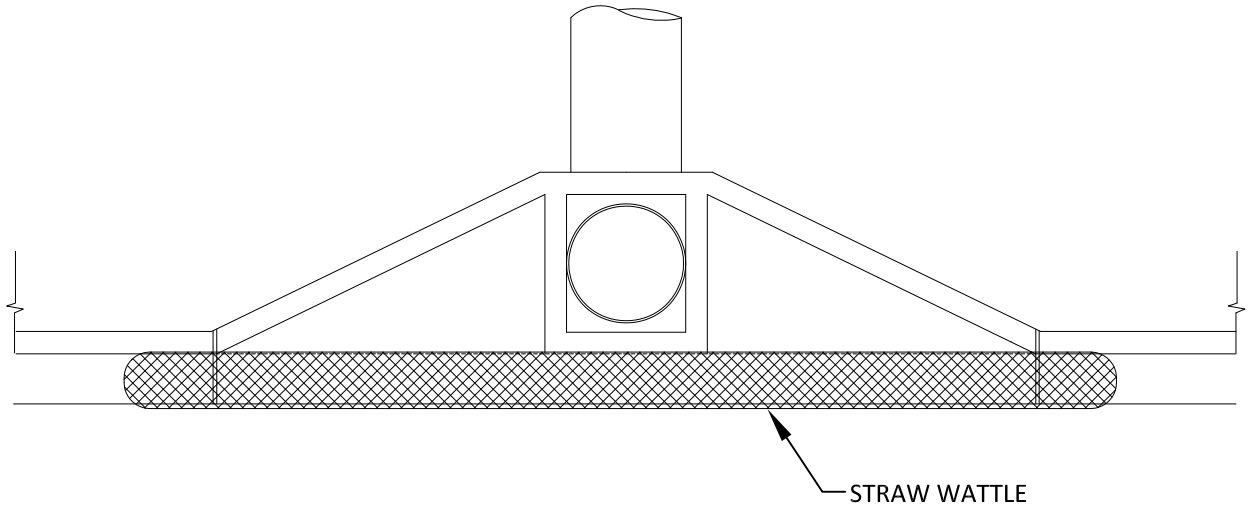

PLAN VIEW

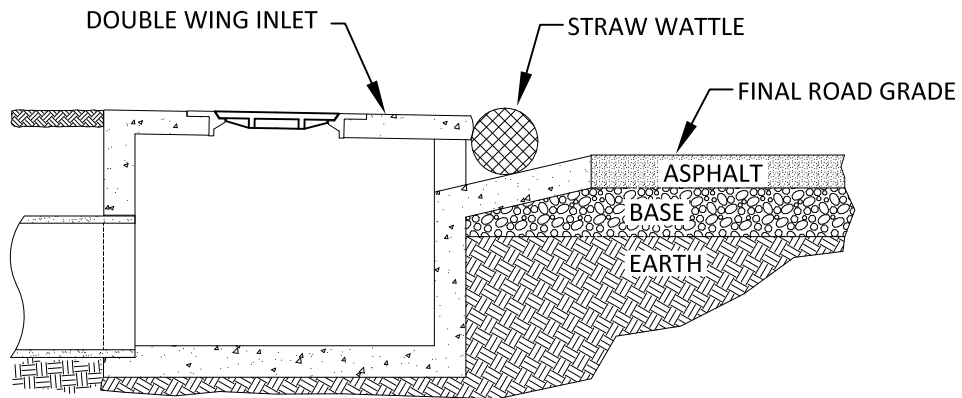

PROFILE VIEW

**NOTE:**

1. TYPE OF INLET MAY DIFFER, BUT WATTLE MUST BE LONGER THAN INLET TO ENSURE PROPER PROTECTION.



**CITY OF MONTGOMERY**  
 STORM WATER MANAGEMENT  
 PROGRAM (SWMP)

DATE  
 9 JULY 2012  
 PREPARED BY  
 D. SMITH  
 APPROVED BY  
 P. DUNSON



DRAWING NO.

**RES-IPW**

# TYPICAL NARRATIVE FOR CONSTRUCTION OF SINGLE FAMILY RESIDENCE

- **Project Description:** (Example) The purpose of this project is for the construction of single-family residences in the City of Montgomery or within the zoning jurisdiction of the City. Single-family dwellings with driveways are being planned for lots xx-xx, block xx, of Plat Name plat Number # of the Name of Development Development in Montgomery County. The total disturbed area of all lots is xx acres.
- **Erosion and Sediment Controls:** All vegetative and structural E/S practices shall at a minimum be constructed and maintained according to the “Minimum Industry Standards” and unless otherwise indicated in accordance with the *Alabama Handbook for Erosion Control, Sediment Control and Stormwater Management on Construction Sites and Urban Areas, March 2009*.
- The following measures shall be used on each property in accordance with standard practices:
  - a) **Sediment Barrie (SB):** SB shall be placed adjacent to the down-slope perimeter of the disturbed area.
  - b) **Construction Exit Pad (CEP):** CEP shall be placed and maintained at the entrance of the property.
  - c) **Permanent Seeding (PS):** Appropriate seeding mixture shall be placed on the total disturbed area within 10 days of final grading to ensure proper stabilization of the disturbed soils.
  - d) **Diversion (DV), Block & Gravel Inlet Protection (BIP), Fabric Drop Inlet Protection (FIP), Rock Filter Dam (RFD) and Sediment Basin (SBN):** controls shall be used depending on such factors as disturbed area, drainage issues, and critical areas such as proximity to floodplain or wetlands, or steep slopes.

**Notes:** Final limits of clearing and grading will be determined when the structures are sited. The clearing of the lots is not to be conducted with the construction of other activities or infrastructure related to this plan unless any disturbed areas are seeded within 14-days of clearing operations completion.



# **CHECKLIST**

## **FOR EROSION AND SEDIMENT CONTROL**

### **PLANS**

\_\_\_\_\_ **Minimum Standards** – All applicable Minimum Standards as described in the *Alabama Handbook for Erosion Control, Sediment Control and Stormwater Management on Construction Sites and Urban Areas*, March 2009, must be addressed.

#### **COMPONENTS of NARRATIVE:**

\_\_\_\_\_ **Project Description** – Briefly describes the nature and purpose of the land-disturbing activity, and the area (acres) to be disturbed.

\_\_\_\_\_ **Existing site conditions** – A description of the existing topography, vegetation and drainage.

\_\_\_\_\_ **Adjacent Areas** – A description of neighboring areas such as streams, lakes, residential areas, roads, etc., which might be affected by the land disturbance.

\_\_\_\_\_ **Off-site areas** – Describe any off-site land-disturbing activities that will occur (including borrow sites, waste or surplus areas, etc.). Will any other areas be disturbed?

\_\_\_\_\_ **Soils** – A brief description of the soils on the site giving such information as soil name, mapping unit, erodibility, permeability, depth, texture and soil structure.

\_\_\_\_\_ **Critical Areas** – A description of areas on the site which have potentially serious erosion problems (e.g., steep slopes, channels, wet weather/underground springs, etc.).

\_\_\_\_\_ **Erosion and sediment control measures** – A description of the methods, which will be used to control erosion and sedimentation on the site.

\_\_\_\_\_ **Permanent Stabilization** – A brief description, including specifications, of how the site will be stabilized after construction is completed

\_\_\_\_\_ **Stormwater runoff considerations** – Will the development site cause an increase in peak runoff rates? Yes\_\_\_ No\_\_\_ Will the increase in runoff cause flooding or channel degradation downstream? Yes\_\_\_ No\_\_\_ Describe the strategy to control stormwater runoff.

\_\_\_\_\_ **Calculations** – Calculations for the design of temporary sediment basins, permanent stormwater detention basins, diversions, channels, etc. Include calculations for pre- and post- development runoff.

\_\_\_\_\_ **Vicinity map** – A small map locating the site in relation to the surrounding area. Include any landmarks, which might assist in locating the site.

\_\_\_\_\_ **Indicate north** – The direction of north in relation to the site along with the plan scale.

\_\_\_\_\_ **Limits of clearing and grading** – Areas which are to be cleared and graded

\_\_\_\_\_ **Existing contours** – The existing contours of the site

\_\_\_\_\_ **Final contours** – Changes to the existing contours, including final drainage patterns

\_\_\_\_\_ **Existing Vegetation**- The existing tree lines, grassed areas, or unique vegetation described.

**CITY OF MONTGOMERY, ALABAMA  
SITE CLEARING, EARTHWORK, GRADING, AND OTHER SITE ACTIVITY  
PERFORMANCE BOND**

BOND NUMBER \_\_\_\_\_

KNOW ALL MEN BY THESE PRESENTS, THAT WE \_\_\_\_\_  
(hereinafter called the Principal) and \_\_\_\_\_  
(hereinafter called the Surety) are held firmly unto the City of Montgomery, Alabama (hereinafter called the Obligee), in full and just sum of \_\_\_\_\_ Dollars (\$ \_\_\_\_\_), lawful money of the United States of America, for the payment of which, well and truly to be made, we bind ourselves, our heirs, administrators, executors and assigns, jointly and severally, firmly by these presents.

WHEREAS, said Principal has applied to the Obligee for a permit to perform site clearing, earthwork, grading, and other site activity on the land as described as follows: \_\_\_\_\_  
\_\_\_\_\_, provided the Principal install the erosion and sedimentation control BMPs in accordance with the approved erosion and sedimentation plans prepared by \_\_\_\_\_, and filed at the City Engineering Department.

NOW THEREFORE, THE CONDITION OF THIS OBLIGATION IS SUCH THAT, if Principal shall promptly and faithfully construct the improvements and achieve **permanent site stabilization** in accordance with the approved erosion and sedimentation plans which are made a part hereof by reference as if set out in here full, and said construction approved by Obligee, then the Bond shall be null and void; otherwise to remain in full force and effect. The bond will automatically extend without amendment for additional one year period from the expiration date, or any future expiration date, until all disturbed areas have been permanently stabilized in accordance with approved erosion and sedimentation plans.

WHENEVER, the Principal shall be, and is declared by Obligee to be in default under this agreement, the Surety may promptly remedy the default; or shall promptly:

1. Complete the **permanent site stabilization**, or
2. Obtain a bid for submission to Obligee for complete and **permanent site stabilization** and upon determination by Obligee and Surety of the lowest responsible bidder, arrange for a contract between such bidder and Obligee and make available as work progresses sufficient funds to pay the cost not to exceed the cost for which the Surety may be liable hereunder, the amount of this bond.

No right of action shall accrue on this bond to or for the use of any persons or corporation other than the Obligee named herein.

SIGNED, SEALED AND DELIVERED THIS \_\_\_\_\_ day \_\_\_\_\_ of \_\_\_\_\_.

PRINCIPAL (COMPANY NAME)
ADDRESS
TELEPHONE NUMBER
FAX NUMBER
OFFICIAL SIGNATURE

SURETY (COMPANY NAME)
ADDRESS
TELEPHONE NUMBER
FAX NUMBER
OFFICIAL SIGNATURE

CITY OF MONTGOMERY, ALABAMA  
SITE CLEARING ACTIVITY ONLY PERFORMANCE BOND

BOND NUMBER \_\_\_\_\_

KNOW ALL MEN BY THESE PRESENTS, THAT WE \_\_\_\_\_  
(hereinafter called the Principal) and \_\_\_\_\_  
(hereinafter called the Surety) are held firmly unto the City of Montgomery, Alabama (hereinafter called the Oblige), in full and just sum of \_\_\_\_\_ Dollars (\$ \_\_\_\_\_), lawful money of the United States of America, for the payment of which, well and truly to be made, we bind ourselves, our heirs, administrators, executors and assigns, jointly and severally, firmly by these presents.

WHEREAS, said Principal has applied to the Oblige for a permit to perform site clearing, earthwork, grading, and other site activity on the land as described as follows: \_\_\_\_\_  
\_\_\_\_\_, provided the Principal install the erosion and sedimentation control BMPs in accordance with the approved erosion and sedimentation plans prepared by \_\_\_\_\_, and filed at the City Engineering Department.

NOW THEREFORE, THE CONDITION OF THIS OBLIGATION IS SUCH THAT, if Principal shall promptly and faithfully construct the improvements and achieve **permanent site stabilization** in accordance with the approved erosion and sedimentation plans which are made a part hereof by reference as if set out in here full, and said construction approved by Oblige, then the Bond shall be null and void; otherwise to remain in full force and effect. The bond will automatically extend without amendment for additional one year period from the expiration date, or any future expiration date, until all disturbed areas have been permanently stabilized in accordance with approved erosion and sedimentation plans.

WHENEVER, the Principal shall be, and is declared by Oblige to be in default under this agreement, the Surety may promptly remedy the default; or shall promptly:

1. Complete the **permanent site stabilization**, or
2. Obtain a bid for submission to Oblige for complete and **permanent site stabilization** and upon determination by Oblige and Surety of the lowest responsible bidder, arrange for a contract between such bidder and Oblige and make available as work progresses sufficient funds to pay the cost not to exceed the cost for which the Surety may be liable hereunder, the amount of this bond.

No right of action shall accrue on this bond to or for the use of any persons or corporation other than the Oblige named herein.

SIGNED, SEALED AND DELIVERED THIS \_\_\_\_\_ day \_\_\_\_\_ of, \_\_\_\_\_.

PRINCIPAL (COMPANY NAME)
ADDRESS
TELEPHONE NUMBER
FAX NUMBER
OFFICIAL SIGNATURE

SURETY (COMPANY NAME)
ADDRESS
TELEPHONE NUMBER
FAX NUMBER
OFFICIAL SIGNATURE

SITE CLEARING, EARTHWORK, GRADING, AND OTHER SITE ACTIVITY  
IRREVOCABLE STANDBY LETTER OF CREDIT NO. \_\_\_\_\_

ISSUE DATE: \_\_\_\_\_

STATED EXPIRATION DATE: \_\_\_\_\_

IN FAVOR OF:  
City of Montgomery, Alabama  
Attn: Engineering Department  
P.O. Box 1111  
Montgomery, Alabama 36101-1111

FOR ACCOUNT OF:  
\_\_\_\_\_  
*Name of Property Owner*  
\_\_\_\_\_  
*Address*  
\_\_\_\_\_  
  
Telephone Number: \_\_\_\_\_

To the City of Montgomery, Alabama:

\_\_\_\_\_ (the "Issuer") hereby establishes its Irrevocable Standby Letter of Credit No. \_\_\_\_\_ (this "Letter of Credit") in favor of the City of Montgomery, Alabama ("Beneficiary") for the account of \_\_\_\_\_ ("Customer") in an amount not exceeding \_\_\_\_\_ U.S. Dollars (\$\_\_\_\_\_) in the aggregate (the "Stated Amount"). These funds shall be available to Beneficiary by draft drawn on Issuer at sight during hours on which Issuer is open for doing business with the public at Issuer's office at \_\_\_\_\_, \_\_\_\_\_ Montgomery, Alabama when accompanied by the following documents:

1. Original of this Letter of Credit; and
2. Beneficiary's officially signed statement reading: "We hereby certify that \_\_\_\_\_ has failed to construct the improvements and achieve **permanent site stabilization** in accordance with the approved construction plans prepared by \_\_\_\_\_ and filed at the City Engineering Department."

Upon such expiration, Issuer shall be fully discharged of all obligations under this Letter of Credit. This Letter is effective as of the issue Date stated above and shall expire on \_\_\_\_\_, however, this Letter of Credit shall be automatically renewed for additional periods of one year each, unless at least 30 days prior to the then expiration date Issuer notifies Beneficiary that issuer will not renew this letter of Credit (such notice being call a "Notice

of Non-Renewal). On the expiration date immediately following delivery of said Notice of Non-Renewal to Beneficiary, this Letter of Credit will expire and Issuer shall be fully discharged of all obligations under this Letter of Credit.

This Letter of Credit may be terminated with written approval from the City of Montgomery. Said approval not to be unreasonably withheld.

Partial drawings are **not** permitted under this Letter of Credit.

This Letter of Credit is non-transferrable, and no valid transfer or assignment hereof shall be authorized or permitted.

This Letter of Credit is subject to the *International Standby Practices* (“ISP98”) published by the International Chamber of Commerce, which is made a part hereof by this reference; and to the extent not inconsistent with the ISP98, this Letter of Credit shall be governed by and construed in accordance with the laws of the State of Alabama, U.S.A.

This Letter of Credit must be presented with any drawing.

ISSUER NAME: \_\_\_\_\_

ADDRESS: \_\_\_\_\_

\_\_\_\_\_

\_\_\_\_\_

Montgomery, AL \_\_\_\_\_

\_\_\_\_\_

*Bank Name*

By: \_\_\_\_\_

*Name, Title*